

ddrum®

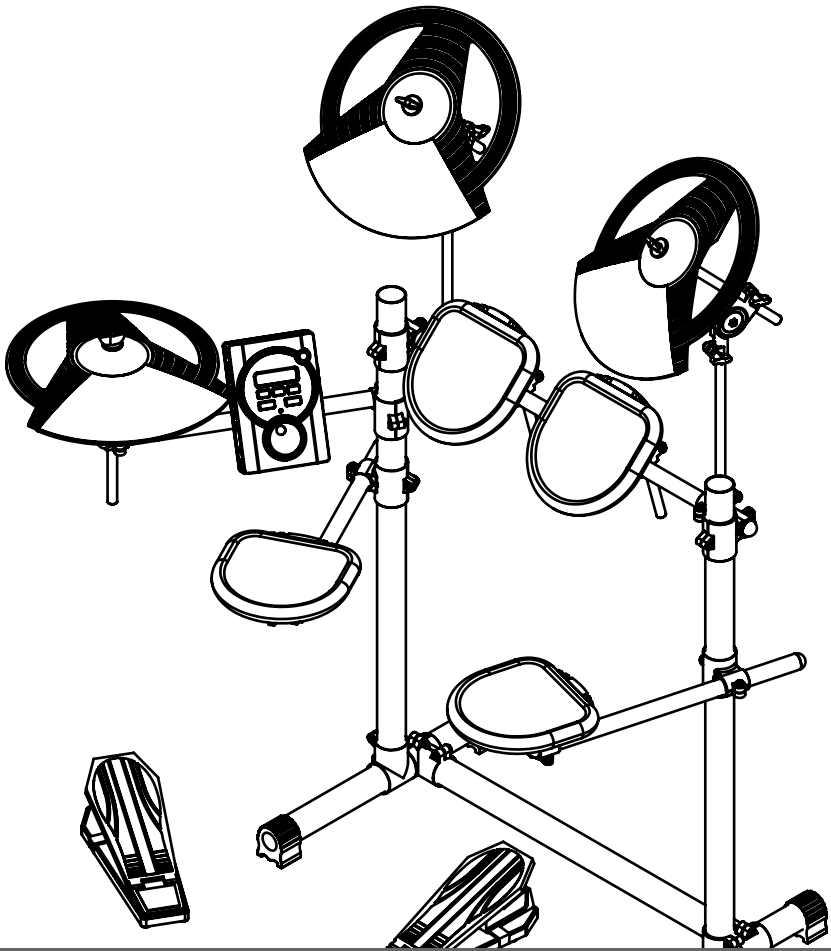



DDBETA

**ELECTRONIC DRUM SET
USER MANUAL**



Operation Warning

Instruction for Prevention of Fire, Electric Shock, & Physical Injury

About Warning & Caution Signs

 WARNING	This sign indicates the risk of serious physical injury or even death. Please operate the machine according to instructions.
 CAUTION	This sign indicates the risk of serious physical injury and even death. Please operate the machine according to instructions. *Object damage refers to any harm or adverse effects to household, furniture, pets, and etc.

About Signs

	This sign indicates a warning or caution. Please read the accompanied instruction to prevent any dangers.
	This sign indicates any forbidden activity.
	This sign indicates an instructional procedure for users to follow with.

**ALWAYS FOLLOW THE INSTRUCTIONS
AS DESCRIBED BELOW**



WARNING

Please read the following instruction before operation.



Do not open or, in any way, modify the machine or adapter.



Do not attempt to repair the machine, or replace any internal parts by yourself, unless instructed to do so by the manual. In case of technical need, please contact with your retailer, or their customer service, or any recognized retailers printed on the information page.



Do not store or operate the machine under the following described conditions:

- Near areas with extreme temperature. (For example, in the car under the sun, near a heat venting pipe, and etc.)
- In very humid environments. (For example, in the bathroom, in the toilet, on wet floor, and etc.)
- Exposing to rain.
- In the sand.
- In shaking & unstable environments.



Operate the machine with the recommended support stands and accessories only.



WARNING

For proper operation, make sure that the support stands are placed on flat and stable ground in order to support the machine safely and stably.



Use only the included adapter. Make sure that the voltage of the socket matches the voltage indicated on your adapter to prevent damage or electric shock.



Please do not over-twist or over-bend the power cable, or place any objects on it. Doing so may result in short-circuit that can lead to fire and electric shock.



Please do not operate the machine with high volume over a long period of time regardless of using an amplifier or a headphone, to prevent damage to your hearing. Should any hearing discomfort results, stop using the machine and consult a hearing doctor.



Prevent letting any object like coins or pins, or any liquid slip inside the machine.





WARNING

Should any of the following situations result, please stop operation and remove the adapter from the socket, and consult with your retailer, the nearest customer service, or any of the recognized retailers listed on the information page:

- The adapter or the power cable is damaged.
- An object, or liquid has slipped into the interior of the machine.
- The machine has been exposed in rain, or has got wet.
- The machine is not operating or is operating with noticeable problems.



If there were children in the household, the adults should be responsible of ateaching the children to follow the safety precautions explained in the manual.



Do not share the power supply with too many adapters at the same time. When using an extension power supply, please make sure that the total power usage does not exceed the limit stated on the extension power supply. Doing so may result in melting of the cables and fire.



When using the machine in other countries, please consult your retailer, the nearest customer service, or any of the recognized retailers listed on the information page.



CAUTION

Always place the machine and the adapter in areas with good airflow.



When inserting or removing the power cable into/from the socket or the machine, always grab the plug instead of the cable.



If you plan not to operate the machine for a long period of time, please remove the adapter from the socket.



To prevent the cables from tangling, place the cables out of reach of children.



Do not place heavy objects on the machine.



When moving the machine, or during insertion/removal of the plug, always use dry hands.



When moving the machine, or during insertion/removal of the plug, always use dry hands.



Please turn off the power and remove the adapter from the socket before cleaning the machine.



When there is a risk of lightning strike, please remove the adapter from the socket.



Precautions

Please read the following precautions aside from the safety instructions

Power Supply

- Do not share the power supply with other electronics that can produce cable statics, for example, electric motors.
- It is normal for direct current (DC) to produce heat with extended usage, and there is no need to be worried.
- Before connecting the machine to other equipments, always turn off the power to prevent damage.

Placement/Location

- Operating the machine near a post-amplifier or machines that use high-power converters, buzzing may result. To prevent this problem, please change the machine's facing direction, or place the machine away from the interrupting sources.
- This machine may interfere with the radios and televisions. Please do not operate the machines near them.
- Do not place the machine under sun, or near any heat source, as high temperature may cause the machine to deform or discolor.
- To prevent permanent damage, please do not expose the machine to moist or in humid environments.

Maintenance

- For normal cleaning, please use soft cloth with little or no moist for wiping. For tougher spots, use neutral-pH and wear-free cleaner then use dry soft cloth to wipe clean.
- Never use volatile oil, diluting solutions, alcohol, or any other kinds of solvents to prevent the machine from deforming or discoloring.

Additional Precautions

- During operation, please handle with care to prevent any damage.
- Do not hit or press against the display screen.
- Always grab the heads of cables during insertion/removal to prevent damage to the cables or the machine.
- To prevent disturbing your neighbors, please operate the machine at an acceptable volume, or use a headphone, especially at nights.
- Although the machine is designed to minimize unwanted noise during operation, the percussive sound may still pass through the floor or walls, resulting in unexpected noise. Please be careful not to let such sound disturb your neighbors, especially at nights.
- When transporting the machine, please use the original or similar stuffing and box.
- Please use official cables for connection. When using cables from other companies, please note the following:

Some cables may consist of resistors, which may be incompatible and result in extremely low volume. For information about the specifications of cables, please consult with the manufacturers.

- Please do not hit the pads with excessive force to prevent the risk of hurting your fingers.

Accessories

A1



Sound Module

x1

A2



Pad

x4

A3



Cymbal

x3

B1



Drum Stick
(1 set)

x1

B2



Headphones

x1

L1

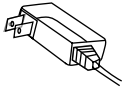

Adapter

x1

L2



L-L Mono
Sound Cable
(Black)

x6

L3

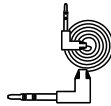

L-L Stereo
Sound Cable
(Red)

x3

B3



Cable Tie

x2

B4



User
Manual

x1

A4



Hi-Hat
Controller

x1

A5



Bass Drum
Controller

x1



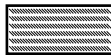



B5



Velcro

x6

Parts

P1	P2	P3	P4	P5	P6	P7
Floor Pad	Ø3.81 (cm) Stopper	Ø2.22 (cm) Stopper	Bolt	Washer	Bolt	Nut
						
x4	x2	x8	x14	x14	x8	x22

Spare Parts

P4~P7

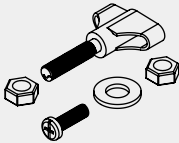

x2

Connectors

C1

Ø2.22 Pad Connector



x2

C2

Ø1.27 Pad Connector



x2

C3

Adjustable Bar

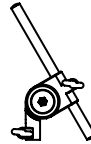

x2





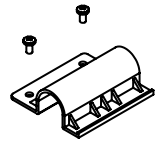





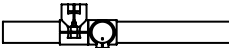

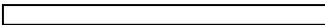
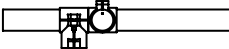
C4

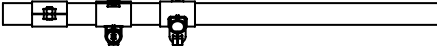
U-shape Plate & Double Screws

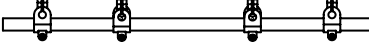

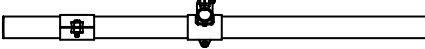
x1

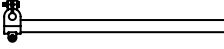
Support Stand

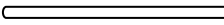
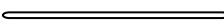
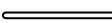
S1		Ø3.81 x40 (cm) x1		x2
S2		Ø3.81 x57 (cm) x1		
S3		Ø3.81 x40 (cm) x1		x2
S4		Ø3.81 x75 (cm) x1		x3
S5		Ø2.22 x65 (cm) x1		x4
S6		Ø3.81 x75 (cm) x1		x2
S7		Ø2.22 x40 (cm) x1		x1
S8		Ø2.22 x40 (cm) x2		
S9		Ø1.27 x40 (cm) x2		
S10		Ø1.27 x20 (cm) x3		

Step 1

S1

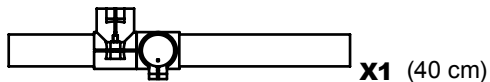

S2

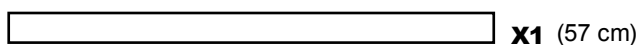

S3

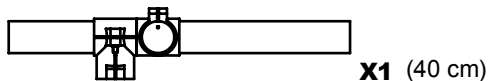

S4

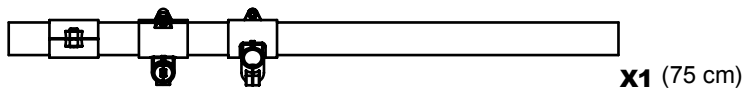

S5

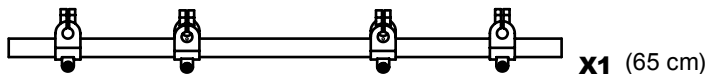

S6

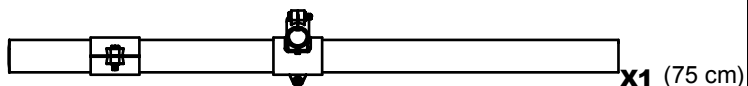

S7

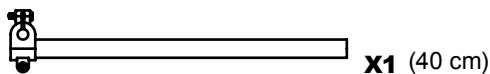

P1

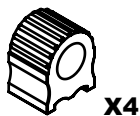

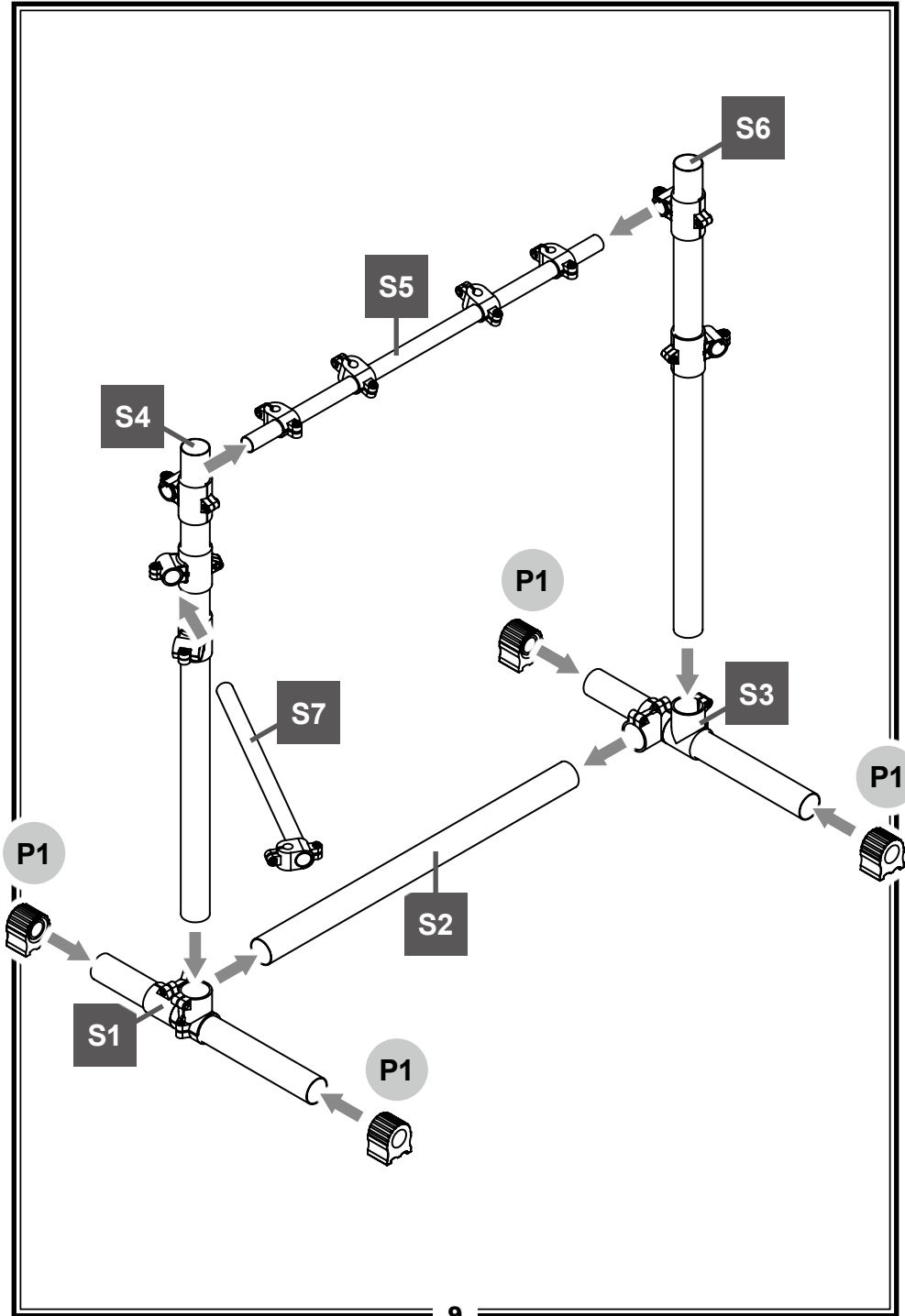

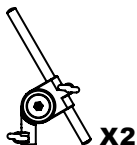

Step 2

C3





S8  Ø2.22 x40 (cm) **x2**

S9  Ø1.27 x40 (cm) **x2**

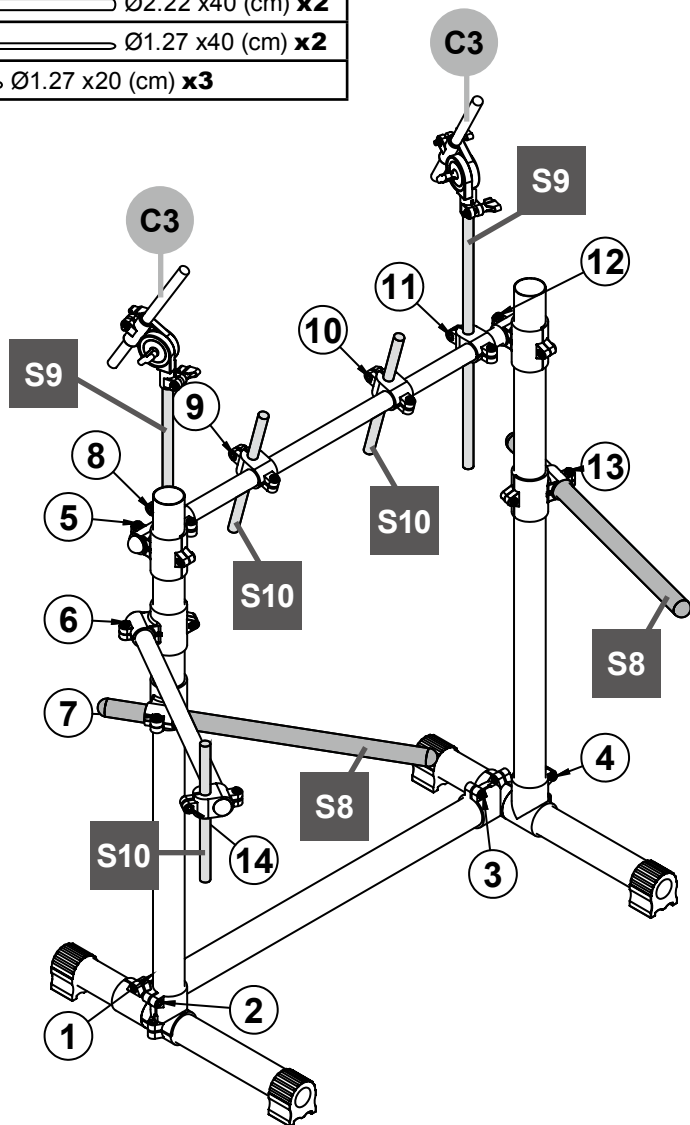
S10  Ø1.27 x20 (cm) **x3**

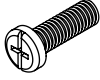

Step 3

P4		x14
P5		x14
P7		X14

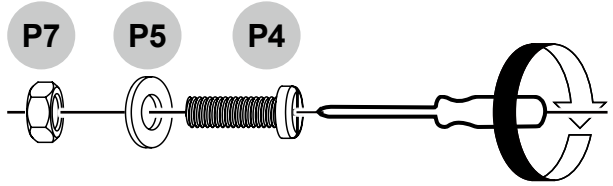

① ② ③ ④

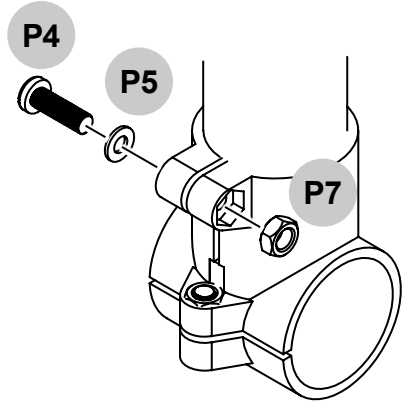



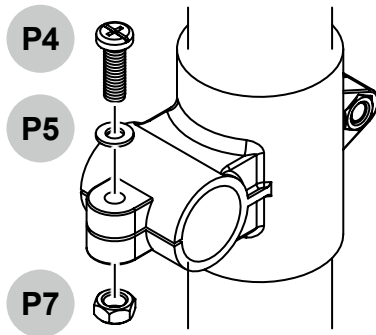

⑤ ⑥ ⑦ ⑫ ⑬

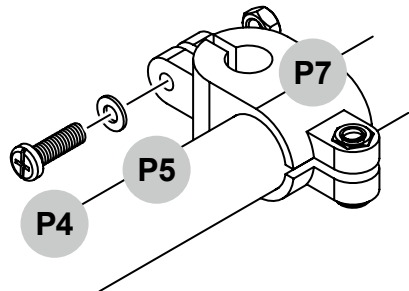

⑧ ⑨ ⑩ ⑪ ⑭



Step 4

A2		x4
P6		x8
P7		x8
C1		x2
C2		x2

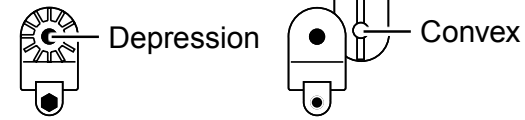
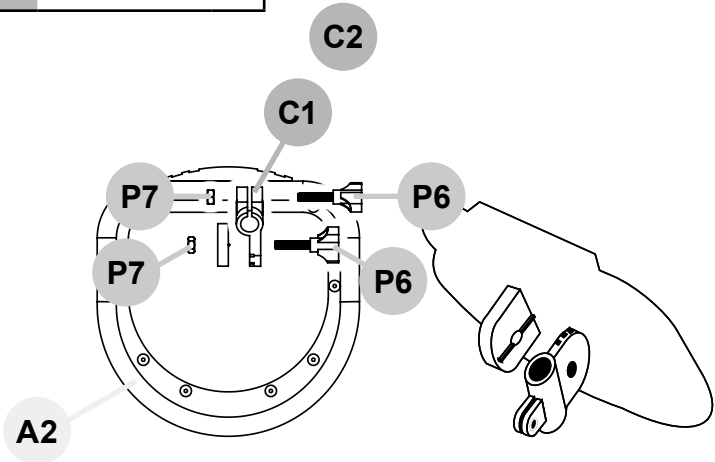

Below are examples of wrong assembly.

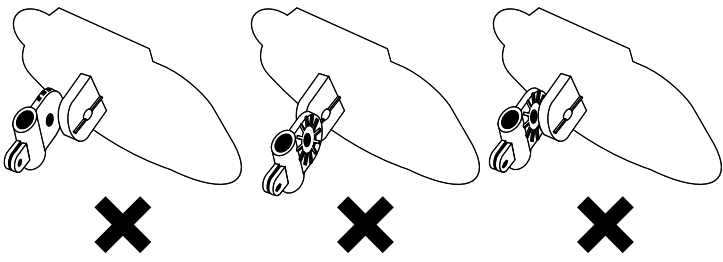

Step 5

A2



x4

A3



x3

P2



x2

P3



x8

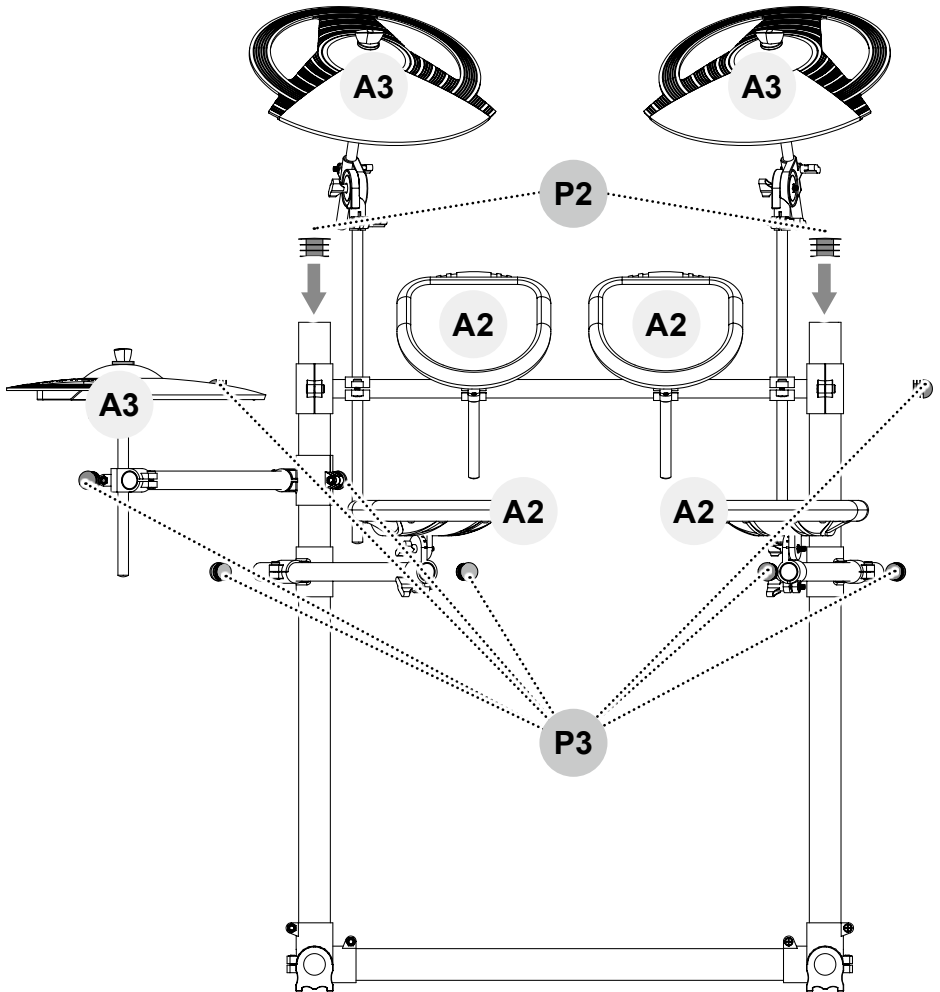

Mounting on the stand

A1



x1

C4



x1

Position the Sound Module onto the Bar and fold the U-Shape Plate upwards around the bar.

Secure the U-Shape Plate to the back of the Sound Module with Screws.

A1

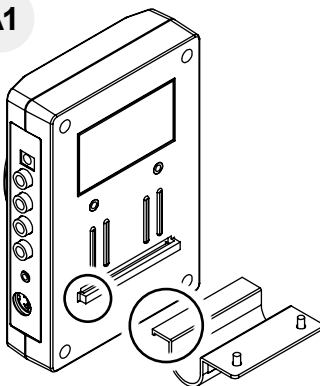

C4

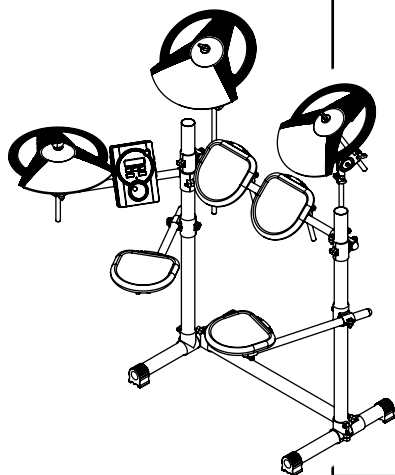
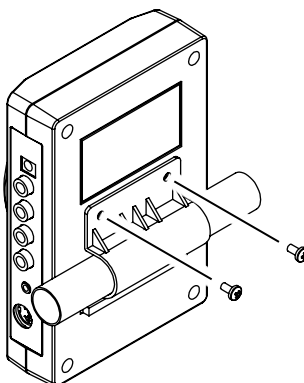
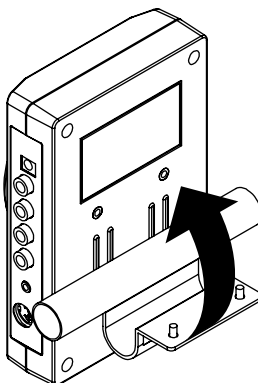

Controller

A4



x1

Hi-Hat
Controller

A5



x1

Bass Drum
Controller

B5

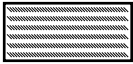

X6

Velcro

Choke Effect

A3



x2

- ④ CYMBAL1
- ⑦ CYMBAL2

A4

reverse side



label:
Hi-Hat

A5

reverse side

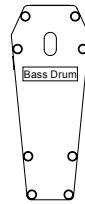

label:
Bass Drum

reverse side

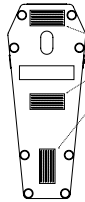

B5

Velcro

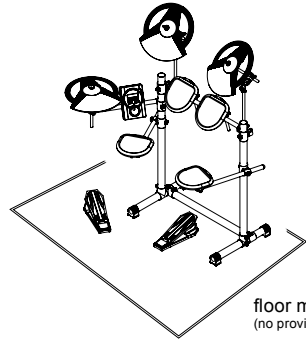

floor mat
(no provide)

A3

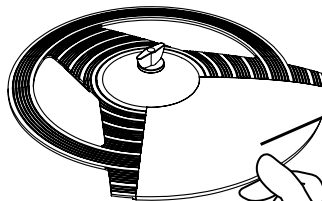

choke effect

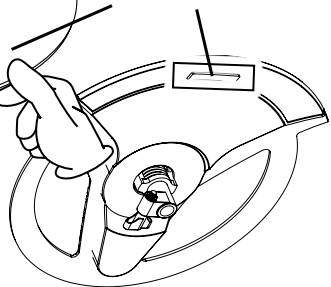

Sound Cable

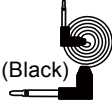
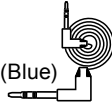
L2	 (Black)	x6
L3	 (Blue)	x3

Connect the Sound Cables to the Drum Pads, Pedals and Sound Module.

Black: mono
Red: stereo

- ② SNARE
- ③ TOM1
- ⑧ TOM2
- ⑨ TOM3

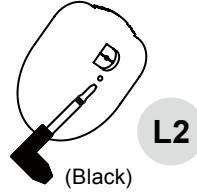

L3

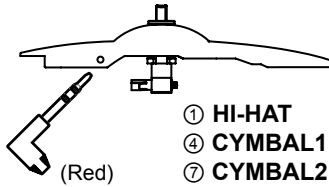

L2

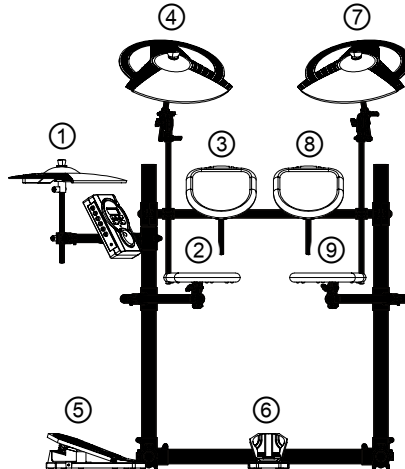

Connecting the Pads

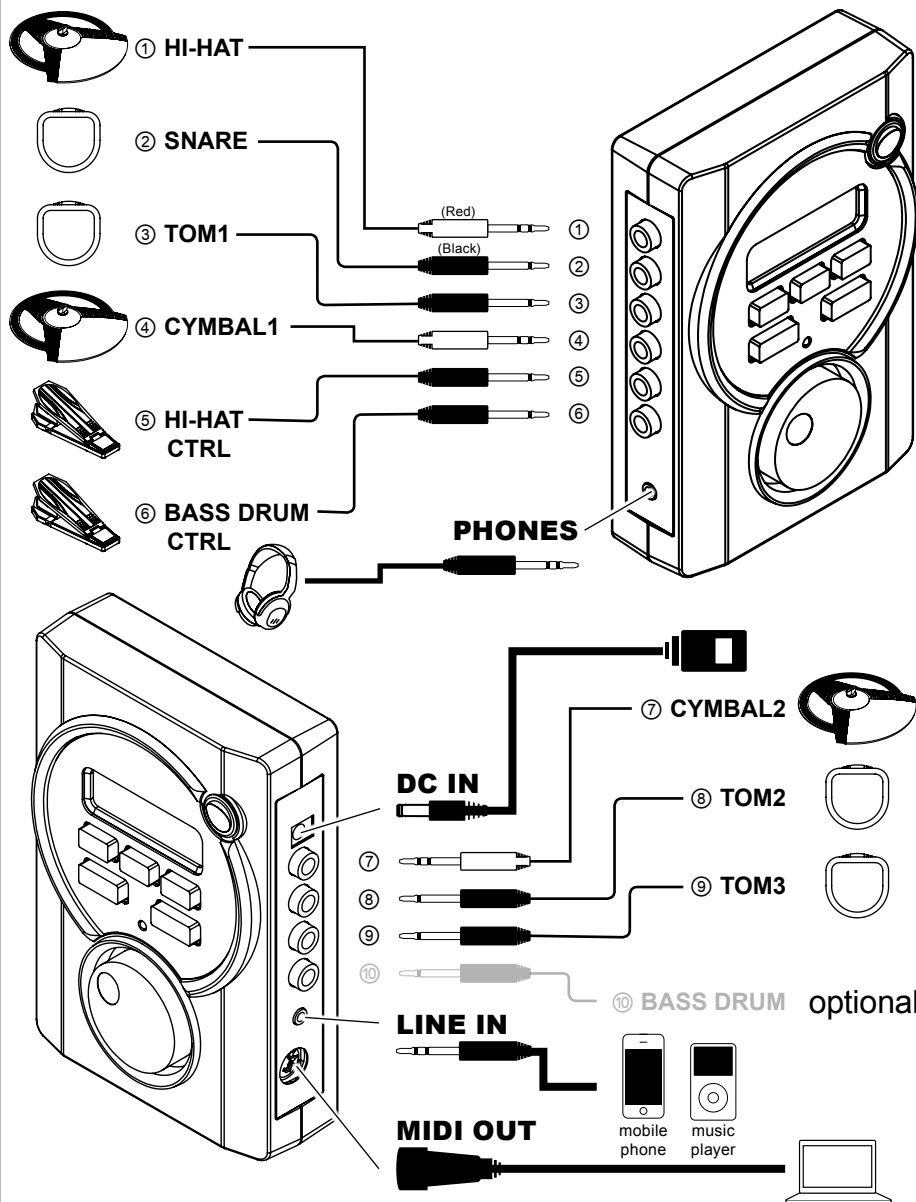

NOTE

① HI-HAT ④ CYMBAL1 and ⑦ CYMBAL2 must use Stereo Sound Cables (red, 2 parallel black lines at the tip) for connection to the Sound Module.

Console Control Introduction

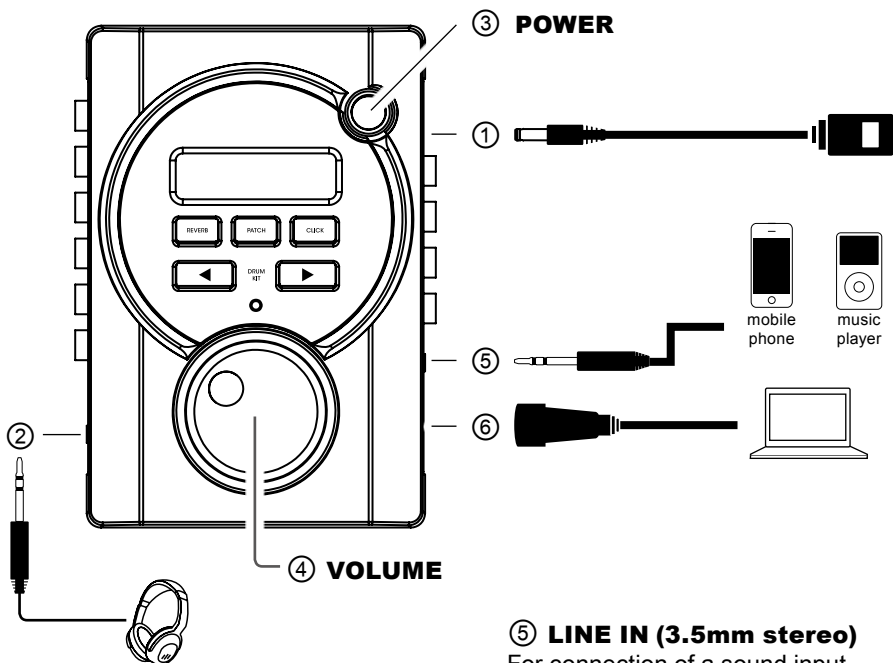

① DC IN (DC 5V1A)

For connection of the power adapter.

② PHONES (3.5mm stereo)

For connection of a headphone.

③ POWER

Switch power on/off.

④ VOLUME

For adjusting the system volume



To prevent damage to speakers, always turn down the volume before inserting or removing sound cables.

③ POWER



⑤ LINE IN (3.5mm stereo)

For connection of a sound input source like a portable music player, a mobile phone, other instruments or another sound source. The sound is directed to PHONES.

⑥ MIDI OUT (5-pin DIN)

For transmitting MIDI data.

About MIDI

MIDI (Musical Instrument Digitable Interface) is an industry-standard protocol that enables electronic musical instruments, computers, and other equipment to communicate, control, and synchronize with each other. MIDI allows computers, synthesizers, MIDI controllers, sound cards, samplers and drum machines to control one another, and to exchange system data.

Console Operation

Percussion Sound Module

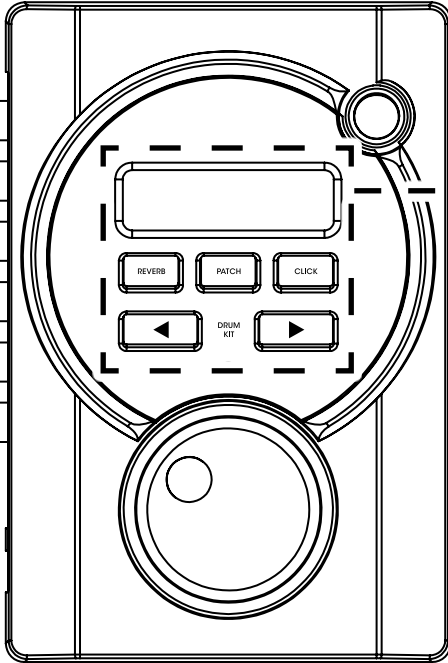

Percussion Sound Module & Metronome

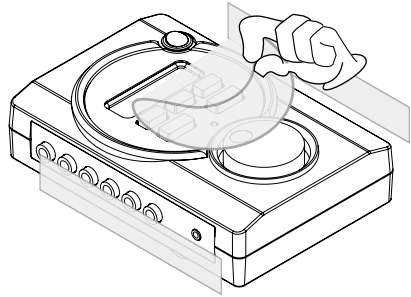

Remove the protector first, it may cause unexpected damage.

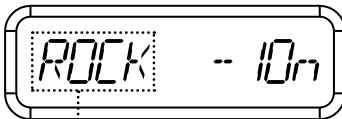

Drum Styles

Press these buttons to Select a Drum Style. The Selected Drum Style will be displayed on the left side of the Sound Module's screen; the picture of the Sound Module, above, displays Selection of ROCK Style. When the Sound Module is turned on, the setting will default to ROCK Style.

Available Drum Styles: ROCK/ JAZZ/ METAL/ BLUES/ POWER/ TECHNO/ MARCH/ LATIN/ TAIKO/ TIMBALE/ FUSION

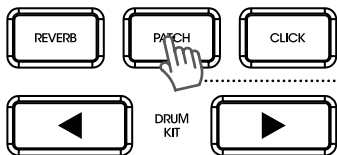
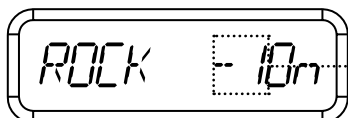

Sound Set

Press this button to Select a Sound Set for the current Drum Style. There are up to 4 Sound Sets per Drum Style. TECHNO, MARCH, and TAIKO Styles only have 1 Sound Set. The Selected Sound Set Number will be displayed to the right of a hyphen on the right side of the screen; the picture of the Sound Module, above, displays Selection of Sound Set 1. When the Sound Module is turned on, the setting will default to Sound Set 1.

DRUM VOICE LIST

ROCK	1 2 3 4	POWER	1 2 3 4	TAIKO	1
JAZZ	1 2 3 4	TECHNO	1	TIMBALE	1 2
METAL	1 2 3 4	MARCH	1	FUSION	1 2 3 4
BLUES	1 2 3 4	LATIN	1 2 3		



Refer to the Styles & Sounds List page for specific percussion sounds.

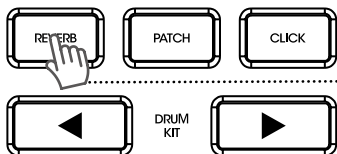
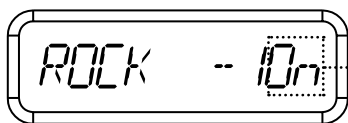

Reverb

Press this button to Toggle Reverb On or Off. The function of Reverb is to simulate the component of sound that results from reflections from surrounding walls or objects, like an

echo. An **On** will be displayed to the right of the Sound Set Number to designate Reverb On. If the Sound Module's screen only displays a Drum Style and a Sound Set, this designates Reverb Off. When the Sound Module is turned on, the setting will default to Reverb Off.

Metronome

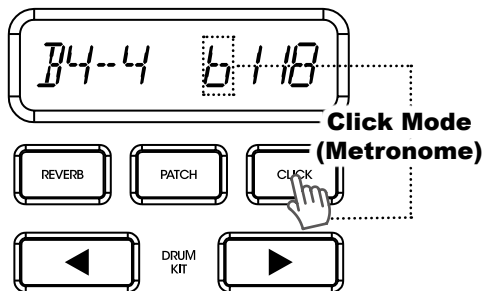

Press this button to Switch to the Metronome Display, above, and Turn On the Metronome. While the Metronome Display is shown, press this button again to Turn Off the Metronome. If the Metronome is not Turned Off nor its settings adjusted, the Metronome Display will eventually revert back to the Drum Style & Sound Set Display, and the Metronome will continue to play.

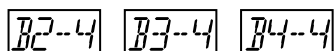
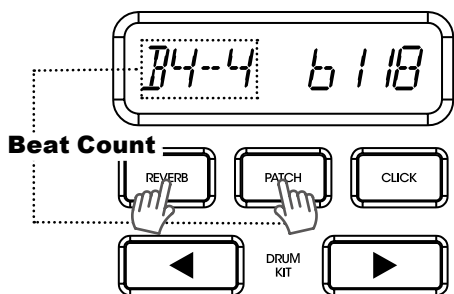

Press this button to Select the Metronome's Beat Count. The picture of the Sound Module, above, displays Selection of Beat Count 3/4. When the Sound Module is turned on and Switched to Metronome, the setting will default to Beat Count 4/4.

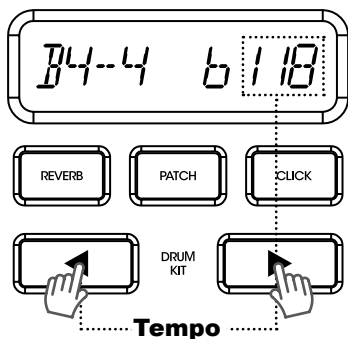

Press these buttons to Adjust the Tempo of the Beat Count. The Tempo will be displayed as a 3 digit number, with a minimum of 30 and a maximum of 250; the picture of the Sound Module, above, displays a Tempo of 118. When the Sound Module is turned on and Switched to Click Mode, the setting will default to a Tempo of 120.

Audio Sampling Frequency	16bit 44.1kHz WAV
Maximum Polyphony	32 notes
Voices	11 Categories, 168 high sound quality audio
Drum kits	32 preset drum modes
Sensor	128 level ultra realistic velocity sensor
Effect	Reverb
Metronome	30-250 BPM, 3 kinds of beats
Wiring Terminal	LINE IN(3.5 Stereo), PHONES(3.5 Stereo), MIDI OUT(5-pin DIN), DC IN(AC adaptor)
Connectors	Hi-Hat, Snare, Tom1, Tom2, Tom3, Cymbal1, Cymbal2, Bass Drum, H.H.Ctrl, Bass Ctrl
Power	DC 5V
Quiescent Current	500mA
Dimensions	17.5(W)x12(D)x5.5(H)cm
Weight	335g



Styles & Sounds List

	1	2	3	4	5	6	7	8	
ROCK	1	HI-HAT	SNARE	TOM1	TOM2	TOM3	CRASH1	CRASH2	BASS
	2	HI-HAT	SNARE	TOM1	TOM2	TOM3	CRASH1	RIDE BELL	BASS
	3	HI-HAT	SNARE	TOM1	TOM2	SIDE STICK	CRASH1	RIDE CYMBAL	BASS
	4	HI-HAT	SNARE	TOM1	TOM2	TOM3	CRASH1	CHINA	COWBELL
JAZZ	1	HI-HAT	SNARE	TOM1	TOM2	TOM3	CRASH1	CRASH2	BASS
	2	HI-HAT	SNARE	TOM1	TOM2	TOM3	CRASH1	RIDE BELL	BASS
	3	HI-HAT	SNARE	TOM1	TOM2	SIDE STICK	CRASH1	RIDE CYMBAL	BASS
	4	HI-HAT	SNARE	TOM1	TOM2	TOM3	CRASH1	CHINA	COWBELL
METAL	1	HI-HAT	SNARE	TOM1	TOM2	TOM3	CRASH1	CRASH2	BASS
	2	HI-HAT	SNARE	TOM1	TOM2	TOM3	CRASH1	RIDE BELL	BASS
	3	HI-HAT	SNARE	TOM1	TOM2	SIDE STICK	CRASH1	RIDE CYMBAL	BASS
	4	HI-HAT	SNARE	TOM1	TOM2	TOM3	CRASH1	CHINA	COWBELL
BLUES	1	HI-HAT	SNARE	TOM1	TOM2	TOM3	CRASH1	CRASH2	BASS
	2	HI-HAT	SNARE	TOM1	TOM2	TOM3	CRASH1	RIDE BELL	BASS
	3	HI-HAT	SNARE	TOM1	TOM2	SIDE STICK	CRASH1	RIDE CYMBAL	BASS
	4	HI-HAT	SNARE	TOM1	TOM2	TOM3	CRASH1	CHINA	COWBELL
POWER	1	HI-HAT	SNARE	TOM1	TOM2	TOM3	CRASH1	CRASH2	BASS
	2	HI-HAT	SNARE	TOM1	TOM2	TOM3	CRASH1	RIDE BELL	BASS
	3	HI-HAT	SNARE	TOM1	TOM2	SIDE STICK	CRASH1	RIDE CYMBAL	BASS
	4	HI-HAT	SNARE	TOM1	TOM2	TOM3	CRASH1	CHINA	COWBELL
TECHNO		HI-HAT	SNARE	TOM1	TOM2	SHOUT	SCRAPE	BEEP	BASS
MARCH		HI-HAT	SNARE	TOM1	TOM2	TOM3	CRASH1	CRASH2	BASS
LATIN	1	RATTLE	LOW CONGA	OPEN HIGH CONGA	FLOOR CONGA	MUTE HIGH CONGA	HIGH WOOD BLOCK	COWBELL	BASS
	2	RATTLE	LOW CONGA	OPEN HIGH CONGA	FLOOR CONGA	HIGH WOOD BLOCK	CRASH1	RIDE BELL	BASS
	3	RATTLE	SIDE CONGA	OPEN HIGH CONGA	FLOOR CONGA	COWBELL	CRASH1	RIDE CYMBAL	BASS
TAIKO		HI-HAT	SNARE	TOM1	TOM2	TOM3	CHINA1	CHINA2	BASS
TIMBALE	1	HI-HAT	CONGA	HIGH TIMBALE	LOW TIMBALE	MUTE HIGH CONGA	SPLASH CYMBAL	RIDE CYMBAL	BASS
	2	HI-HAT	SIDE STICK	HIGH TIMBALE	LOW TIMBALE	COWBELL	SPLASH CYMBAL	RIDE CYMBAL	BASS
FUSION	1	HI-HAT	SNARE	TOM1	TOM2	TOM3	CRASH1	CRASH2	BASS
	2	HI-HAT	SNARE	TOM1	TOM2	TOM3	CRASH1	RIDE BELL	BASS
	3	HI-HAT	SNARE	TOM1	TOM2	SIDE STICK	CRASH1	RIDE CYMBAL	BASS
	4	HI-HAT	SNARE	TOM1	TOM2	TOM3	CRASH1	CHINA	COWBELL

ddrum[®]

For more information please visit our website

www.ddrum.com